

BUTTONS AUDIO

Note: Using U1 Internal pull-ups on all buttons

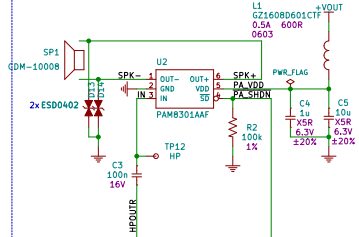

USB DEVICE

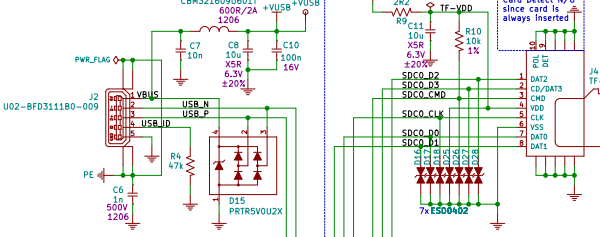

SD CARD POWER

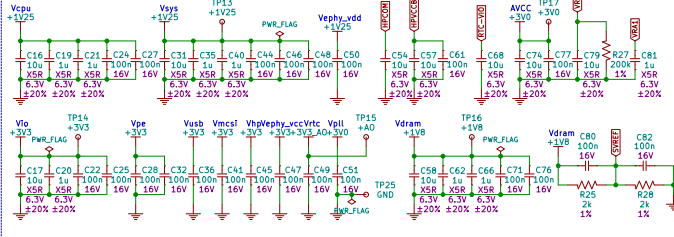

CPU PMIC

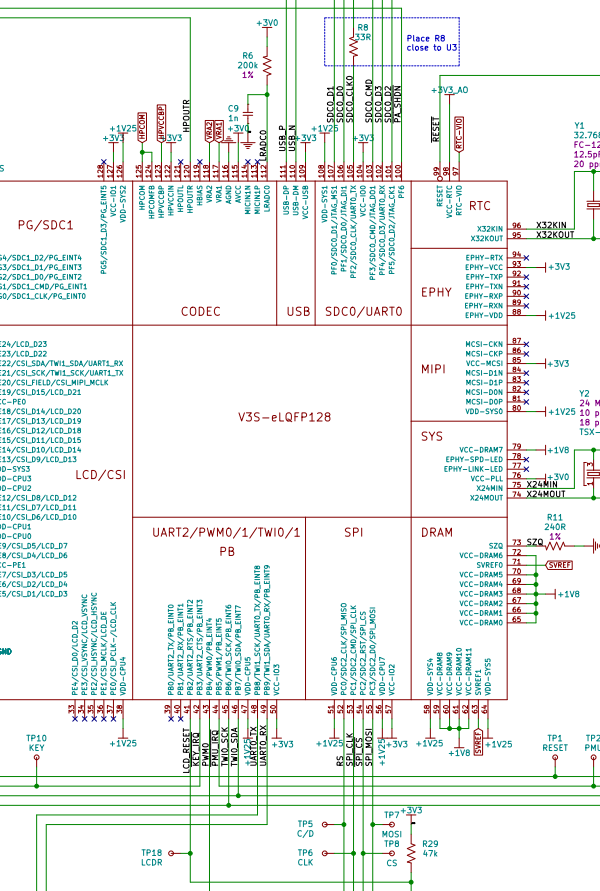
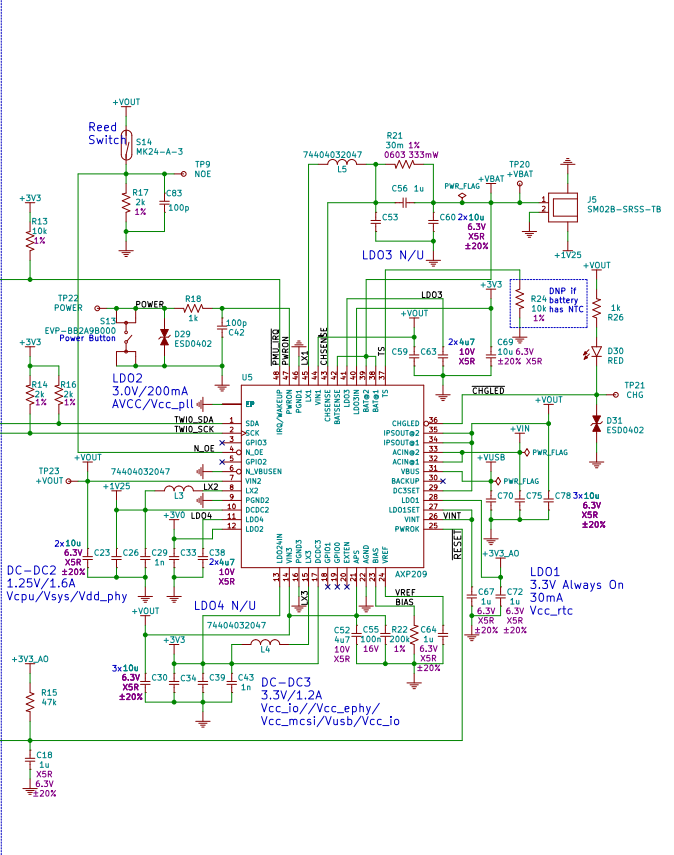

CONSOLE

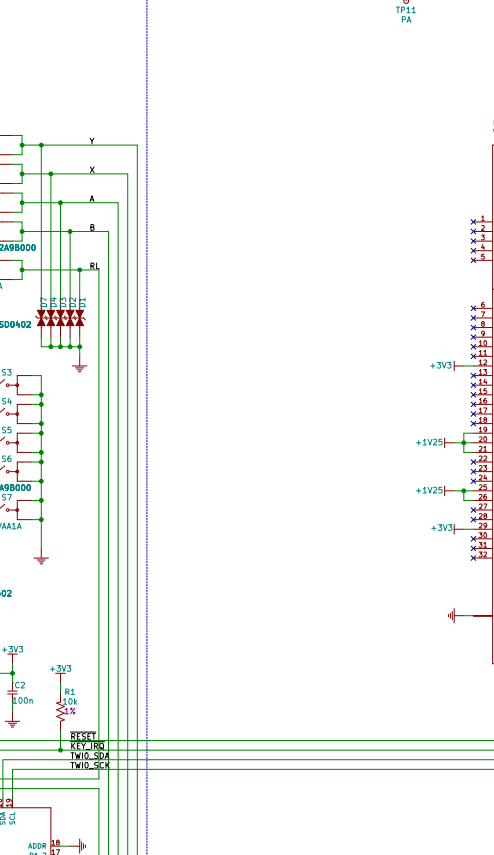

SPI LCD

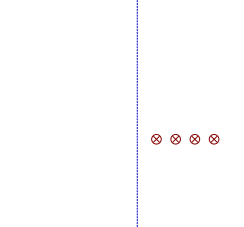

DRAM POWER

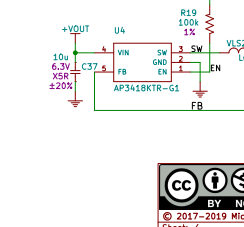

Resistors are 5% 1/16W 0402 unless otherwise specified
Ceramic capacitors are ±10% 50V X7R dielectric 0402 unless otherwise specified